



Bandsaw
Model BS-VE-1981-E
Item 10270
Instruction Manual



Revised - 05/29/2023



Toll Free: 1-800-465-0234
Fax: 905-607-0234
Email: service@omcan.com
www.omcan.com



Table of Contents

Model BS-VE-1981-E

Section	Page
General Information -----	3 - 4
Safety and Warranty -----	4 - 5
Technical Specifications -----	6
Installation -----	6
Operation -----	6 - 7
Maintenance -----	7 - 8
Parts Breakdown -----	9 - 17
Electrical Schematics -----	18
Warranty Registration -----	19



General Information

Omcan Manufacturing and Distributing Company Inc., Food Machinery of America, Inc. dba Omcan and Omcan Inc. are not responsible for any harm or injury caused due to any person's improper or negligent use of this equipment. The product shall only be operated by someone over the age of 18, of sound mind, and not under the influence of any drugs or alcohol, who has been trained in the correct operation of this machine, and is wearing authorized, proper safety clothing. Any modification to the machine voids any warranty, and may cause harm to individuals using the machine or in the vicinity of the machine while in operation.

CHECK PACKAGE UPON ARRIVAL

Upon receipt of an Omcan shipment please inspect for external damage. If no damage is evident on the external packaging, open carton to ensure all ordered items are within the box, and there is no concealed damage to the machine. If the package has suffered rough handling, bumps or damage (visible or concealed), please note it on the bill of lading before accepting the delivery and contact Omcan within 24 hours, so we may initiate a claim with the carrier. A detailed report on the extent of the damage caused to the machine must be filled out within three days, from the delivery date shown in the shipping documents. Omcan has no recourse for damaged products that were shipped collect or third party.

Before operating any equipment, always read and familiarize yourself with all operation and safety instructions.

Omcan would like to thank you for purchasing this machine. It's of the utmost importance to save these instructions for future reference. Also save the original box and packaging for shipping the equipment if servicing or returning of the machine is required.

Omcan Fabrication et distribution Compañie Limité et Food Machinery d'Amérique, dba Omcan et Omcan Inc. ne sont pas responsables de tout dommage ou blessure causé du fait que toute personne ait utilisé cet équipement de façon irrégulière. Le produit ne doit être exploité que par quelqu'un de plus de 18 ans, saine d'esprit, et pas sous l'influence d'une drogue ou d'alcool, qui a été formé pour utiliser cette machine correctement, et est vêtu de vêtements de sécurité approprié. Toute modification de la machine annule toute garantie, et peut causer un préjudice à des personnes utilisant la machine ou des personnes à proximité de la machine pendant son fonctionnement.

VÉRIFIEZ LE COLIS DÈS RÉCEPTION

Dès réception d'une expédition d'Omcan veuillez inspecter pour dommages externes. Si aucun dommage n'est visible sur l'emballage externe, ouvrez le carton afin de s'assurer que tous les éléments commandés sont dans la boîte, et il n'y a aucun dommage dissimulé à la machine. Si le colis n'a subi aucune mauvaises manipulations, de bosses ou de dommages (visible ou cachée), notez-le sur le bond de livraison avant d'accepter la livraison et contactez Omcan dans les 24 heures qui suivent, pour que nous puissions engager une réclamation auprès du transporteur. Un rapport détaillé sur l'étendue des dommages causés à la machine doit être rempli dans un délai de trois jours, à compter de la date de livraison indiquée dans les documents d'expédition. Omcan n'a aucun droit de recours pour les produits endommagés qui ont été expédiés ou cueilli par un tiers transporteur.

General Information

Avant d'utiliser n'importe quel équipement, toujours lire et vous familiariser avec toutes les opérations et les consignes de sécurité.

Omcan voudrais vous remercier d'avoir choisi cette machine. Il est primordial de conserver ces instructions pour une référence ultérieure. Également conservez la boîte originale et l'emballage pour l'expédition de l'équipement si l'entretien ou le retour de la machine est nécessaire.

Omcan Empresa De Fabricacion Y Distribucion Inc. Y Maquinaria De Alimentos De America, Inc. dba Omcan y Omcan Inc. no son responsables de ningun daño o perjuicio causado por cualquier persona inadecuada o el uso descuidado de este equipo. El producto solo podra ser operado por una persona mayor de 18 años, en su sano juicio y no bajo alguna influencia de droga o alcohol, y que este ha sido entrenado en el correcto funcionamiento de esta máquina, y ésta usando ropa apropiada y autorizada. Cualquier modificación a la máquina anula la garantía y puede causar daños a las personas usando la máquina mientras esta en el funcionamiento.

REVISE EL PAQUETE A SU LLEGADA

Tras la recepcion de un envio Omcan favor inspeccionar daños externos. Si no hay daños evidentes en el empaque exterior, Habra el carton para asegurarse que todos los articulos solicitados estén dentro de la caja y no encuentre daños ocultos en la máquina. Si el paquete ha sufrido un manejo de poco cuidado, golpes o daños (visible o oculto) por favor anote en la factura antes de aceptar la entrega y contacte Omcan dentro de las 24 horas, de modo que podamos iniciar una reclamación con la compañía. Un informe detallado sobre los daños causados a la máquina debe ser llenado en el plazo de tres días, desde la fecha de entrega que se muestra en los documentos de envío. Omcan no tiene ningun recurso por productos dañados que se enviaron a recoger por terceros.

Antes de utilizar cualquier equipo, siempre lea y familiarizarse con todas las instrucciones de funcionamiento y seguridad.

Omcan le gustaría darle las gracias por la compra de esta máquina. Es de la mayor importancia para salvar estas instrucciones para futuras consultas. Además, guarda la caja original y el embalaje para el envío del equipo si servicio técnico o devolución de la máquina que se requiere.

Safety and Warranty

CAUTION - NOT MEANT FOR FROZEN PRODUCT

MAIN PRECAUTIONS

When incorrectly used, a bandsaw can be a potentially dangerous machine. Cleaning, maintenance or service must always be done by experienced operators, and with the machine disconnected from the electricity supply.



Safety and Warranty

- NEVER use tools not belonging to the machine to help operation.
- KEEP hands off the moving parts of the machine.
- NEVER connect the power source with wet hands or wet clothes.
- ALWAYS ground the machine properly.
- NEVER touch the blade even when it is not in use because its edge is very sharp, it can cause serious cuttings.
- NEVER adjust the cutting regulator (optional) with the blade in motion.
- NEVER use clothes with loosen sleeves specially near the wrist during the cutting operation.
- USE steel gloves during the cutting operation.
- NEVER switch on the machine with one of its doors opened.
- NEVER spray water or other liquid substances directly at motor, power switch or any other electrical components.
- KEEP your working area clean and dry to prevent it from becoming slippery.
- ALWAYS install equipment in working area with adequate light and space away from CHILDREN and visitors.
- NEVER operate without all warning labels attached and owner/operator manual available to operator.
- NEVER leave unattended while operating.
- STOP the machine immediately if you hear abnormal noises, of fear that injuries may occur.
- CONTACT your distributor if you have any problems with the installation and operation of this machine.

RESIDENTIAL USERS: Vendor assumes no liability for parts or labor coverage for component failure or other damages resulting from installation in non-commercial or residential applications. The right is reserved to deny shipment for residential usage; if this occurs, you will be notified as soon as possible.

1 YEAR PARTS AND LABOUR WARRANTY

Within the warranty period, contact Omcan Inc. at 1-800-465-0234 to schedule an Omcan authorized service technician to repair the equipment locally.

Unauthorized maintenance will void the warranty. Warranty covers electrical and part failures, not improper use.

Please see <https://omcan.com/disclaimer> for complete info.

WARNING:

The packaging components are classified as normal solid urban waste and can therefore be disposed of without difficulty.

In any case, for suitable recycling, we suggest disposing of the products separately (differentiated waste) according to the current norms.

DO NOT DISCARD ANY PACKAGING MATERIALS IN THE ENVIRONMENT!

Technical Specifications

Model	BS-VE-1981-E
Blade Length	78" / 1981mm
Cutting Capacity	7.8" x 7.5" / 197 x 191mm
Cutting Table	Sliding
Power	1 HP / 0.75 kW
Electrical	110-120V / 60Hz / 1
Weight	248 lbs. / 112.7 kgs.
Packaging Weight	287 lbs. / 130.5 kgs.
Packaging Dimensions	26" x 32" x 46" / 660 x 813 x 1168mm
Item Number	10270

Installation

Be sure to install the bandsaw in an easily accessible area with plenty of space.

Grounding wire must always be connected.

IMPORTANT: Check the tension of the blade by turning the handle clockwise before operating it.

Operation

BEFORE OPERATION

Check and make sure the machine is in a stable location. Wash with warm water and soap all the food-contact parts, and wipe dry. To do it, proceed as follows:

1. Switch the machine off and disconnect it from the power source.
2. Open the upper door and lower door by pulling the handle.
3. Loosen the blade turning the handle or calibrator (optional) clockwise and take it out from the upper and lower wheels.
4. Take out the staples which are in front of the upper and lower wheels to be able to pull them out.
5. Assemble the components following the inverse steps.

IMPORTANT: The blade must be well calibrated. Use the handle turning it clockwise to get the right tension of the blade. Keep the machine off to adjust the cutting regulator.

OPERATION

Switch on the machine pressing the on/off switch.

Operation

Put the product to be processed onto the table, pushing it to the direction of the blade lined up by the cutting regulator (optional), maintaining the thickness of the slice desired.

When pulling back the product do not touch the blade avoiding disconnecting it from the wheels.

Drop a little bit of water onto the fixed table to facilitate the slipping of the product.

Maintenance

COMPONENTS ADJUSTMENT

PULLEY BELT

- The belt must be firmly fixed to prevent it from skidding. Do not tighten it too much because it can wear out quickly.
- To have access to the belt remove the screws with a screwdriver from the inferior back lid and take it out.
- With a screw-wrench loosen the screws turning it counter-clockwise. To stretch out the belt you have to push the motor with the wood lever tightening the screws.

IMPORTANT: The pulleys must be lined up.

UPPER BEARING ADJUSTMENTS

- The purpose of this adjustment is to centralize the blade on the gear and avoid it falling down.
- First of all disconnect the machine from the electricity supply. Then loosen blade turning handle counter-clockwise.
- Take out upper back lid by removing screws using the screwdriver. Loosen the three screw-nuts using a 10mm screw-wrench.
- Using the screwdriver turn the screw-nut $\frac{1}{4}$ counter-clockwise if the wheel is inclined towards the front or turn it $\frac{1}{4}$ clockwise if it is inclined backwards. Tighten the three screw-nut previously loosen. Calibrate the blade according to pre-operation.
- Turn the wheels manually to check if the blade is centralized, if it is not keep turning the wheels until the blade is centralized.

CUTTING REGULATOR

- The cutting regulator (optional) was designed to provide cuts with the same thickness and also to protect the operator from getting injured.
- To adjust the cutting regulator proceed as follows:
 - Turn locking knob counter-clockwise to be able to move the cutting regulator to the left and right according to the distance you want to leave from it to the blade.
- Then turn the locking knob clockwise to fix the cutting regulator in the desired position.

CLEANING

First of all disconnect the machine from power source.

Maintenance

- Remove the upper door by unscrewing the screws of the hinges.
- Remove the lower door doing as above.
- Remove the blade by turning blade calibrator knob counter-clockwise, then loosen the blade and pull it out.
- Take out upper and lower wheels by pulling staples out, which are located in front of the wheels.
- Never use hard tools such as: knives, forks, hooks, or others to remove stuck pieces of cut meat from the upper and lower doors. To do that use a plastic brush.
- Assemble the components following the inverse steps.

NOTE: The sharp edge of the blade must be facing the front of the machine.

All removable components must be washed with warm water and neutral soap. Be careful when washing the blade. It has a sharp edge that could cause serious irreparable injuries to the hands.

CAUTION: The machine is not protected against water jets. Do not clean it with steam jets, or high pressure blasts or similar methods. Under no circumstances should the bandsaw be hose rinsed as this may result in short circuit or serious damage to the machine.

Clean the body of the machine with a damp clean cloth and wipe dry.

Parts Breakdown

Model BS-VE-1981-E 10270

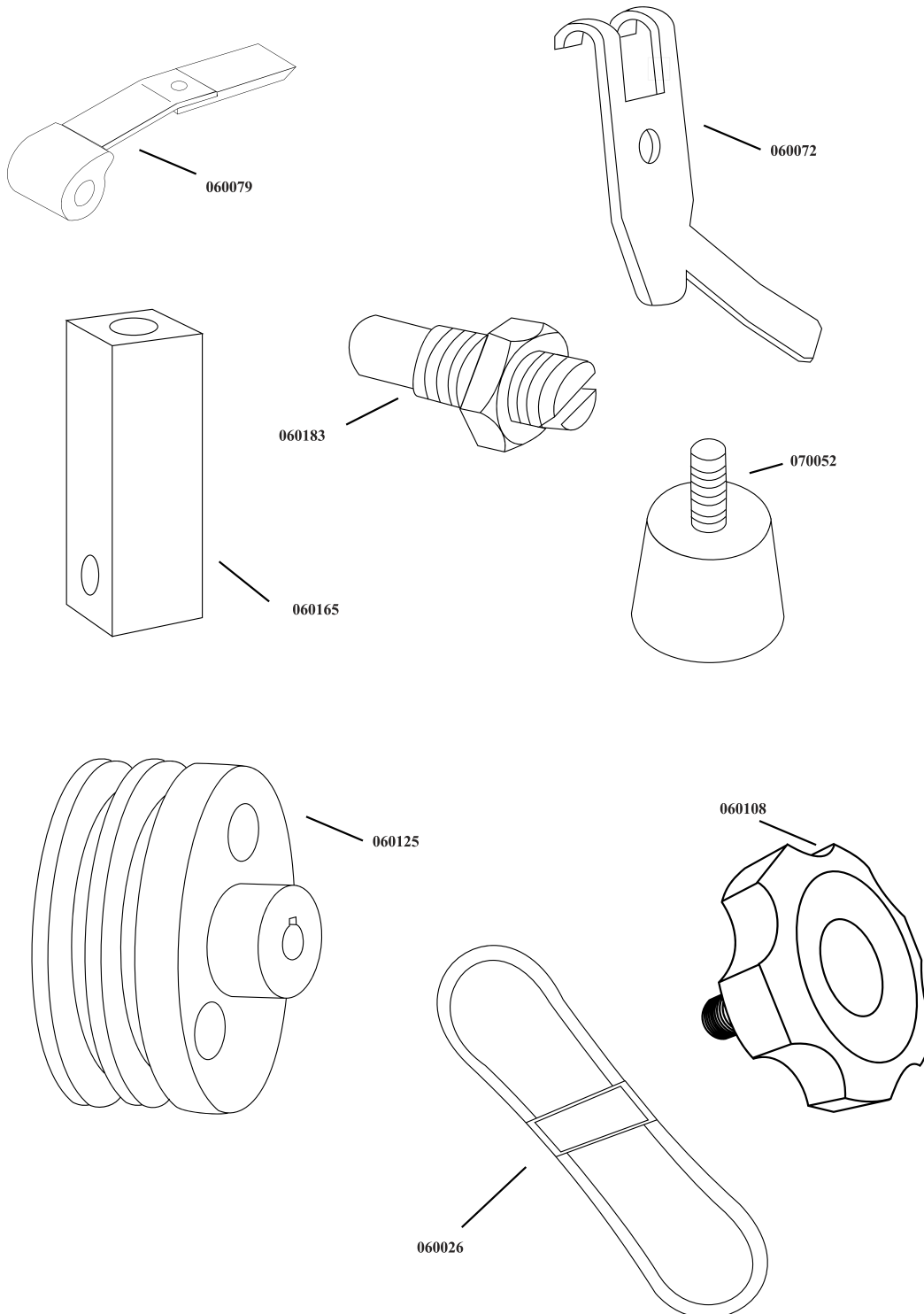

Parts Breakdown

Model BS-VE-1981-E 10270

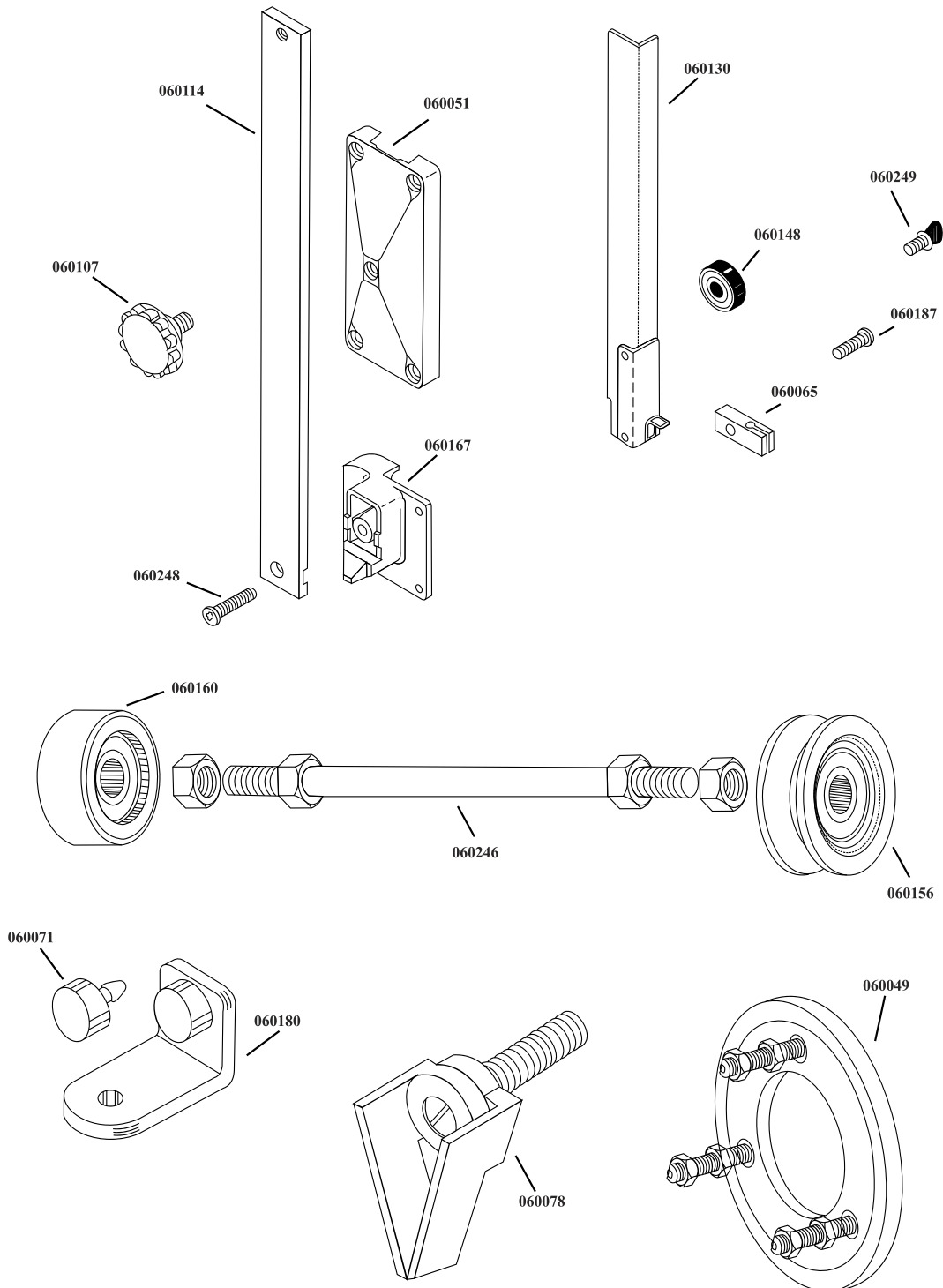

Parts Breakdown

Model BS-VE-1981-E 10270

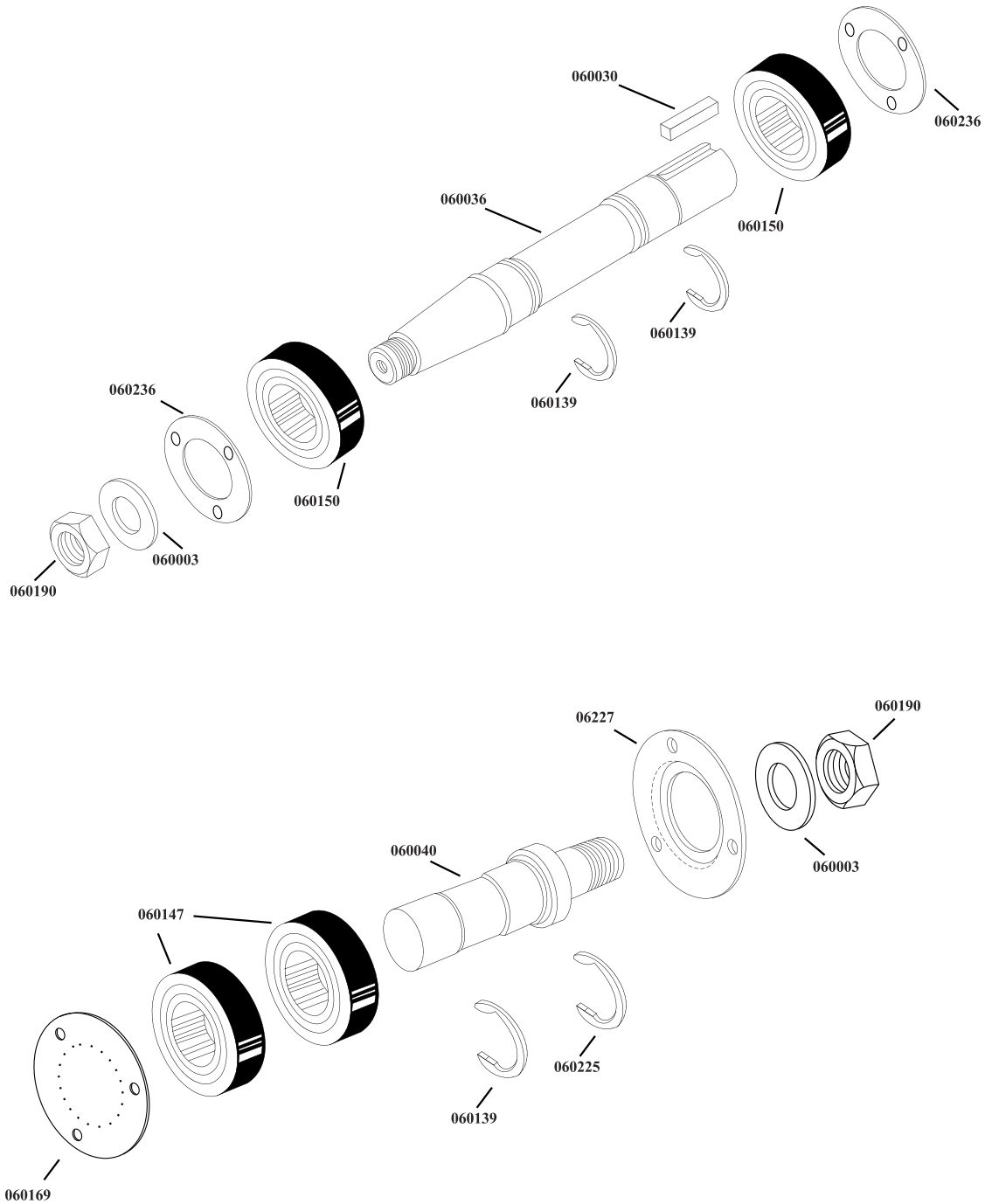

Parts Breakdown

Model BS-VE-1981-E 10270

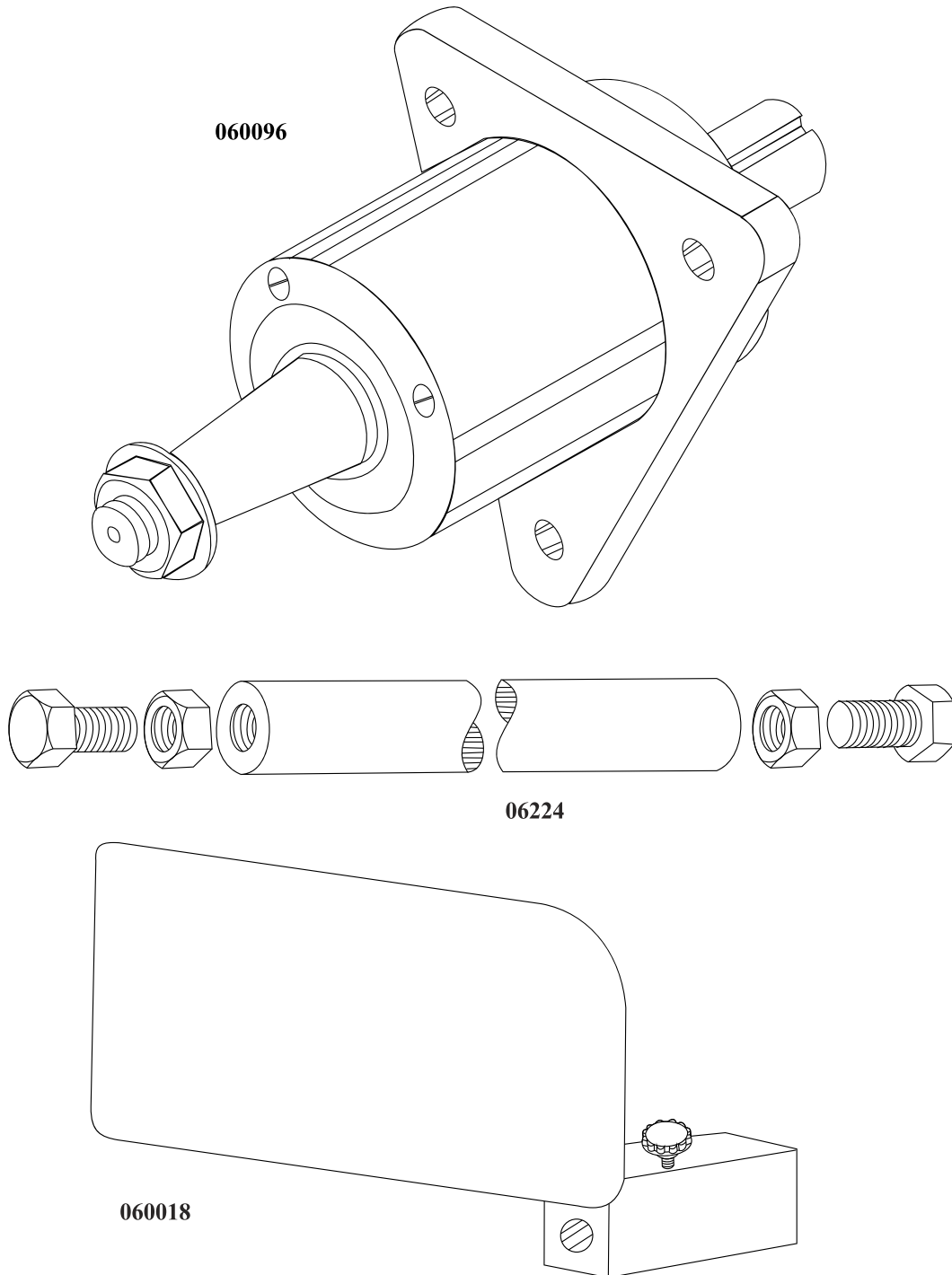

Parts Breakdown

Model BS-VE-1981-E 10270

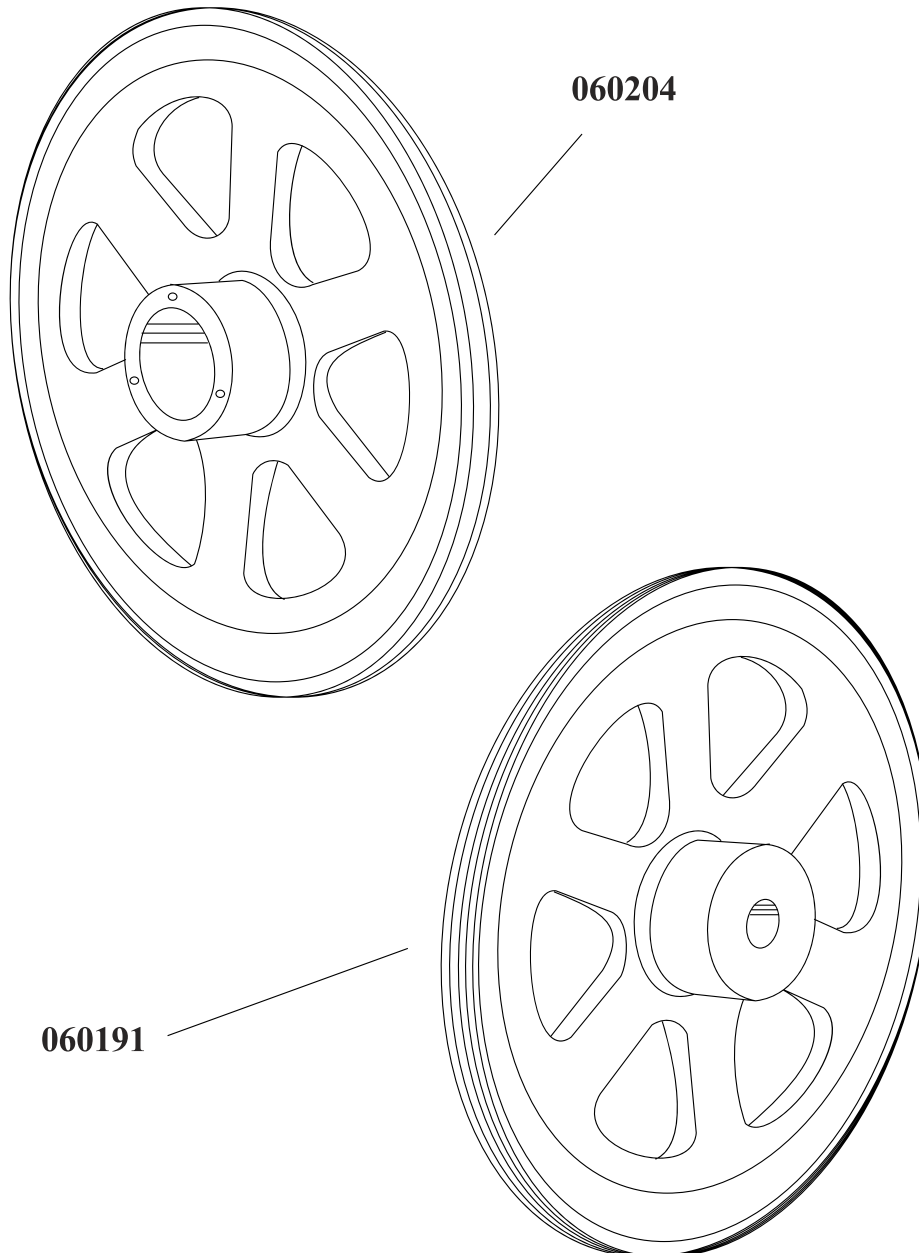

Parts Breakdown

Model BS-VE-1981-E 10270

060200

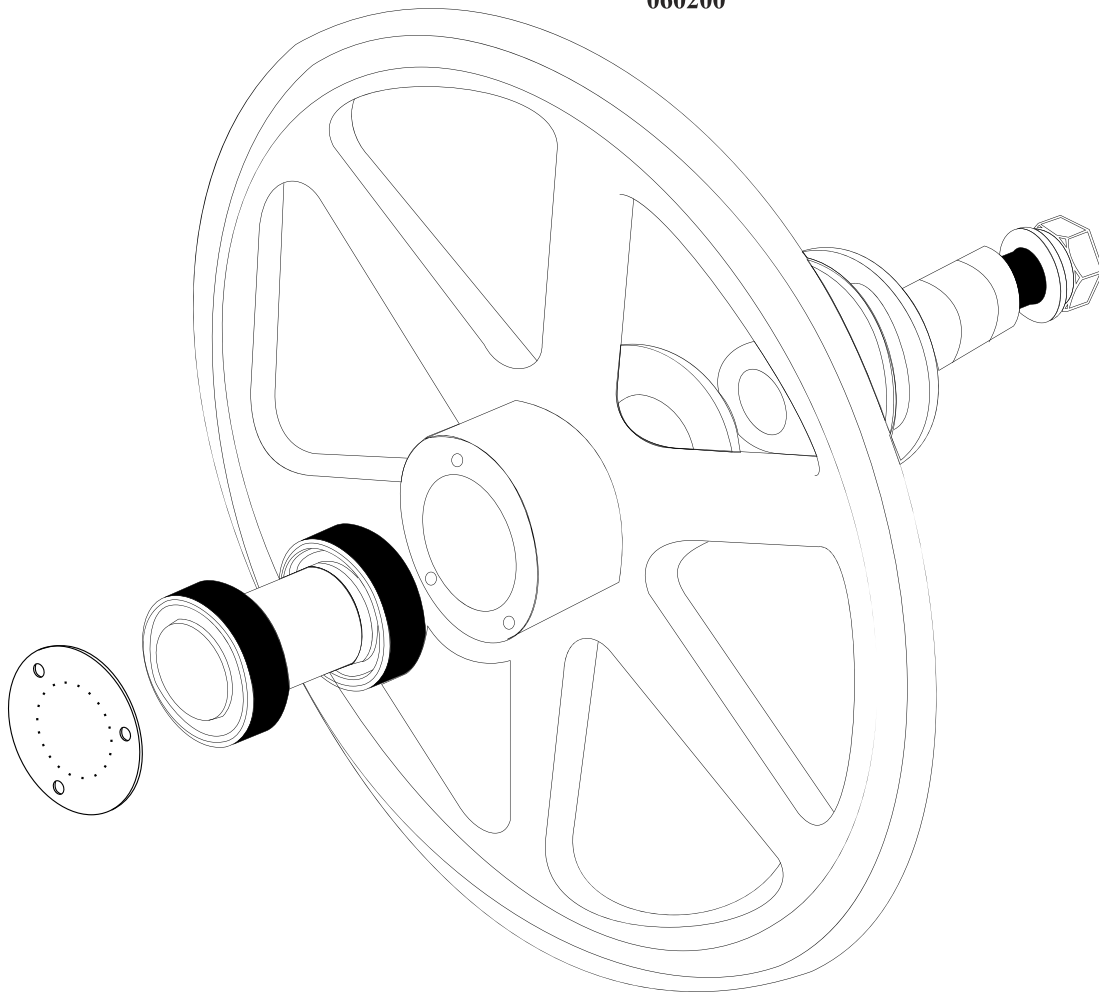

Parts Breakdown

Model BS-VE-1981-E 10270

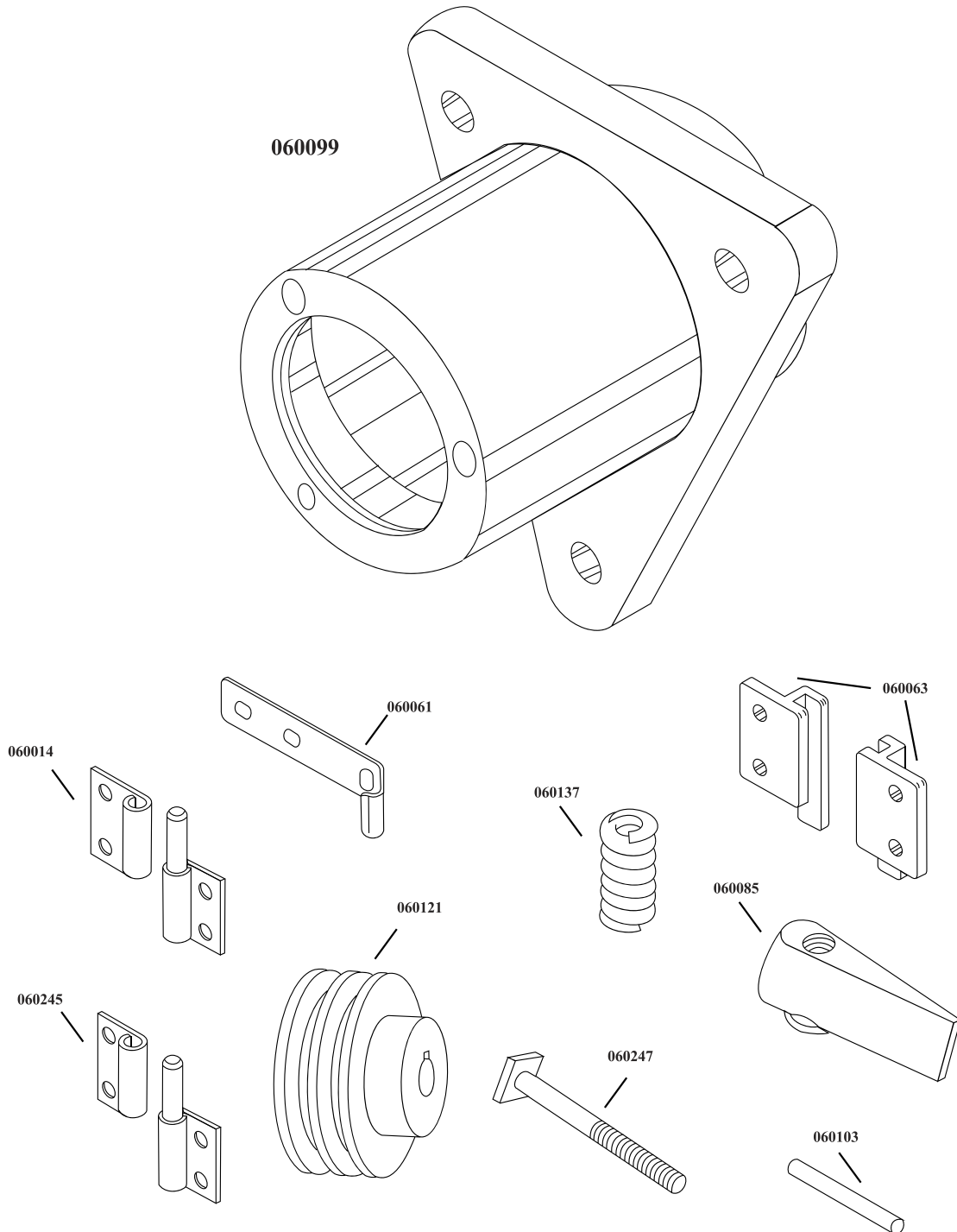



Parts Breakdown

Model BS-VE-1981-E 10270

Item No.	Description	Position	Item No.	Description	Position	Item No.	Description	Position
62104	Arm Shaft for 10270	06224	64596	Butterfly of Sierra for 10270	060085	62092	Sealed Steering Wheel Cover for 10270	060169
64816	Flywheel Front Cover for 10270	06227	17709	Complete Housing Assembly for 10270	060096	62093	Complete Car Iron Bumper for 10270	060180
45115	Washer for 10270	060003	62076	Aluminum Housing for 10270	060099	62094	Graduated Screw for 10270	060183
62061	Long Door Hinge for 10270	060014	24154	Pin for 10270	060103	26129	Long Screw for Aluminum Guide for 10270	060187
62062	Full Arm Shield for 10270	060018	62078	Tightening Knob for 10270	060107	44012	Lower Shaft Nut for 10270	060190
62063	Belt for 10270	060026	16869	Knob for 10270	060108	62097	Hollow Conical Lower Steering Wheel for 10270	060191
62064	Shaft Pin for 10270	060030	62080	Front Aluminum Plate for 10270	060114	17714	Complete Upper Pulley Assembly for 10270	060200
17703	Shaft for 10270	060036	62081	Dual Channel Motor Pulley for 10270	060121	62098	Cylindrical Hollow Top Flywheel for 10270	060204
40165	Shaft for 10270	060040	62082	Double Channel Trapezoidal Pulley for 10270	060125	40167	Lock 471/20 for Upper Axis for 10270	060225
62065	Aluminum Flange for 10270	060049	62083	Blade Protector for 10270	060130	17718	Cover for 10270	060236
62066	Aluminum Front for 10270	060051	62084	Hairpin Spring for 10270	060137	62099	Door Hinge for 10270	060245
17706	Complete Tension Assembly for 10270	060053	17710	Clip for 10270	060139	62100	Wheel Axle for Carriage for 10270	060246
62068	Steel Door Hanger for 10270	060061	62085	Upper Flywheel Bearing 6004 for 10270	060147	62101	Tension Screw for 10270	060247
15587	Fluted Guide for 10270	060063	45067	Bearing 6200 for 10270	060148	62102	Front Plate Screw for 10270	060248
64592	Upper Steel Guide for 10270	060065	16872	Bearing 6205-2RS1 for 10270	060150	64570	Tension Screw for 10270	060249
AJ570	Rubber Stopper for 10270	060071	64815	Complete Grooved Wheel for 10270	060156	62105	Rubber Foot for 10270	070052
62072	Fork for 10270	060072	64569	Front Platinum for 10270	060160	39414	Motor 110/60/1 for 10270	
17707	Scraper for 10270	060078	62090	Steel Bracket for 10270	060165	23717	On/Off Switch Assembly for 10270	
64579	Scraper for 10270	060079	62091	Aluminum Support for 10270	060167			

Electrical Schematics

Model **BS-VE-1981-E** 10270

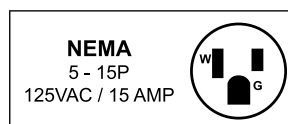
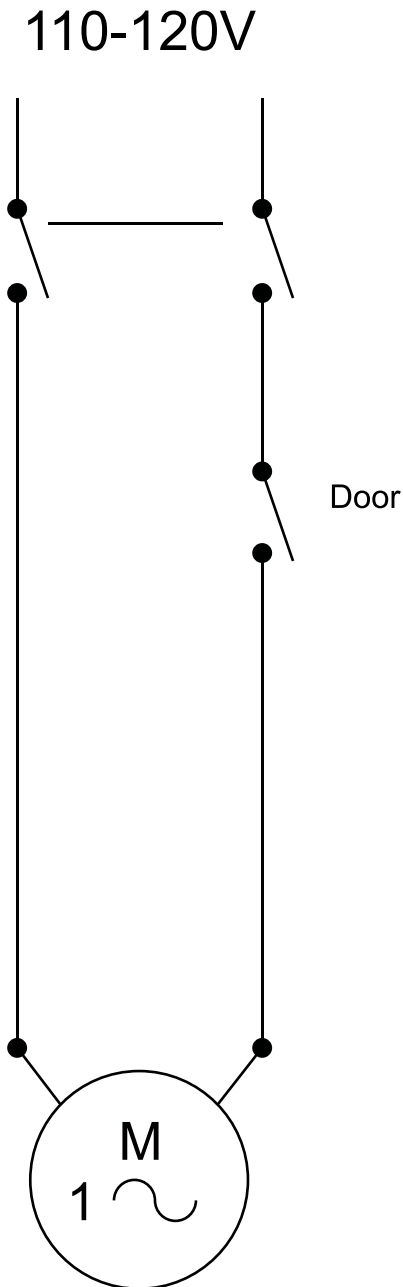



Warranty Registration

Thank you for purchasing an Omcan product. To register your warranty for this product, complete the information below, tear off the card at the perforation and then send to the address specified below. You can also register online by visiting:

Merci d'avoir acheté un produit Omcan. Pour enregistrer votre garantie pour ce produit, complétez les informations ci-dessous, détachez la carte au niveau de la perforation, puis l'envoyer à l'adresse spécifiée ci-dessous. Vous pouvez également vous inscrire en ligne en visitant:

Gracias por comprar un producto Omcan usted. Para registrar su garantía para este producto, complete la información a continuación, cortar la tarjeta en la perforación y luego enviarlo a la dirección indicada a continuación. También puede registrarse en línea en:

<https://omcan.com/warranty-registration/>

For mailing in Canada

Pour postale au Canada

Por correo en Canadá

OMCAN

PRODUCT WARRANTY REGISTRATION

3115 Pepper Mill Court,

Mississauga, Ontario

Canada, L5L 4X5

For mailing in the US

Pour diffusion aux États-Unis

Por correo en los EE.UU.

OMCAN

PRODUCT WARRANTY REGISTRATION

4450 Witmer Industrial Estates, Unit 4,

Niagara Falls, New York

USA, 14305

or email to: service@omcan.com



Purchaser's Information

Name: _____

Address: _____

City: _____ Province or State: _____ Postal or Zip: _____

Country: _____

Dealer from which Purchased: _____

Dealer City: _____ Dealer Province or State: _____

Invoice: _____

Model Name: _____ Model Number: _____

Machine Description: _____

Date of Purchase (MM/DD/YYYY): _____

Would you like to extend the warranty? Yes No

Company Name: _____

Telephone: _____

Email Address: _____

Type of Company:

Restaurant Bakery Deli

Butcher Supermarket Caterer

Institution (*specify*): _____

Other (*specify*): _____

Serial Number: _____

Date of Installation (MM/DD/YYYY): _____

Thank you for choosing Omcan | Merci d'avoir choisi Omcan | Gracias por elegir Omcan



Since 1951 Omcan has grown to become a leading distributor of equipment and supplies to the North American food service industry. Our success over these many years can be attributed to our commitment to strengthen and develop new and existing relationships with our valued customers and manufacturers. Today with partners in North America, Europe, Asia and South America, we continually work to improve and grow the company. We strive to offer customers exceptional value through our qualified local sales and service representatives who provide convenient access to over 6,500 globally sourced products.

Depuis 1951 Omcan a grandi pour devenir un des “leaders” de la distribution des équipements et matériel pour l’industrie des services alimentaires en Amérique du Nord. Notre succès au cours de ces nombreuses années peut être attribué à notre engagement à renforcer et à développer de nouvelles et existantes relations avec nos clients et les fabricants de valeur. Aujourd’hui avec des partenaires en Amérique du Nord, Europe, Asie et Amérique du Sud, nous travaillons continuellement à améliorer et développer l’entreprise. Nous nous efforçons d’offrir à nos clients une valeur exceptionnelle grâce à nos ventes locales qualifiées et des représentants de service qui offrent un accès facile à plus de 6500 produits provenant du monde entier.

Desde 1951 Omcan ha crecido hasta convertirse en un líder en la distribución de equipos y suministros de alimentos en América del Norte industria de servicios. Nuestro éxito en estos años se puede atribuir a nuestro compromiso de fortalecer y desarrollar nuevas relaciones existentes con nuestros valiosos clientes y fabricantes. Hoy con socios de América del Norte, Europa, Asia y América del Sur, que trabajan continuamente para mejorar y crecer la empresa. Nos esforzamos por ofrecer a nuestros clientes valor excepcional a través de nuestro local de ventas y representantes de los servicios que proporcionan un fácil acceso a más de 6,500 productos con origen a nivel mundial.

